

# INSTRUCCIONES MONTAJE VARIADOR J.COSTA

## IT530XRP/PRO - IT5307XRP - IT560XRP/PRO - IT605XRP/PRO

1. Retirar la tapa que cubre la transmisión donde se sitúa el variador.



2. Retirar el variador instalado y limpiar todos los residuos de grasa, aceite y polvo. Conservar las arandelas del variador original.

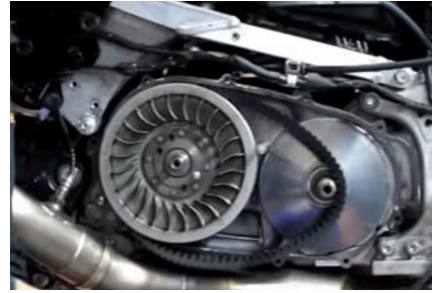

3. Introducir arandela J.Costa.

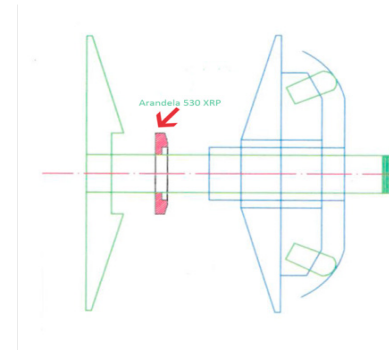

4. Colocar el variador J.Costa, respetando el orden de las arandelas del variador original.

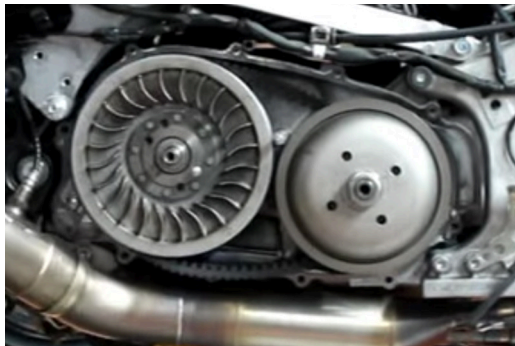

5. Bloquear polea corrector de par.

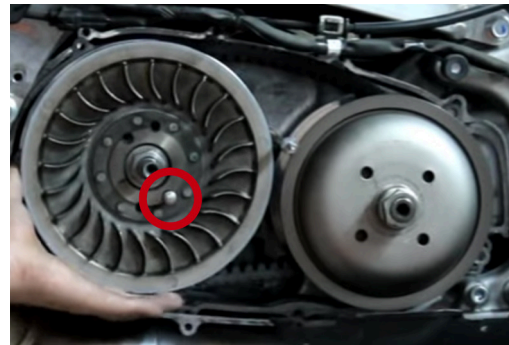

6. Colocar herramienta para bloquear el variador y apretar con dinamometrica a **16kg/160Nm**.



DESPICE VARIADOR T-MAX 530

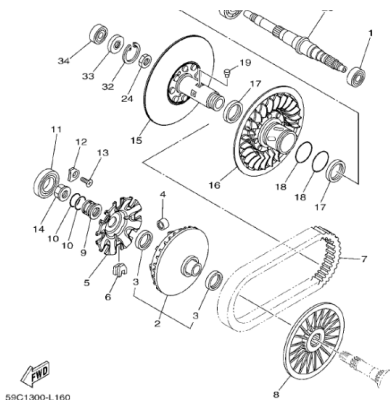

DESPICE VARIADOR T-MAX 500

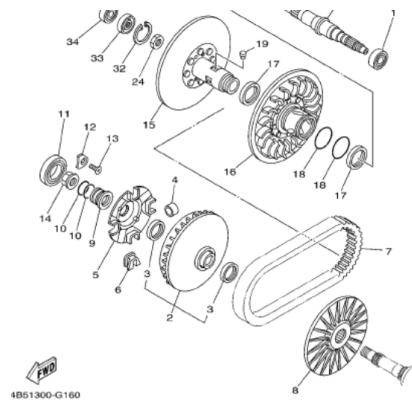

DESPICE VARIADOR T-MAX 560

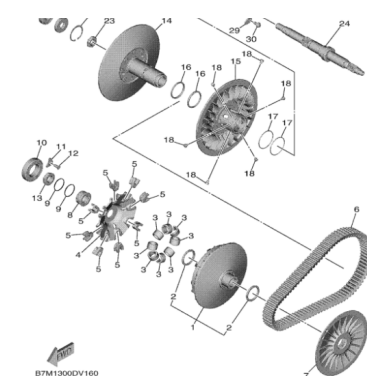

# J.COSTA VARIATOR ASSEMBLY INSTRUCTIONS

## IT530XRP/PRO - IT5307XRP - IT560XRP/PRO - IT605XRP/PRO

1. Before mounting the variator your must remove the cover.



2. Remove the installed variator and clean all grease or oil. Install any washers to the original location. Always in the same position as it were.

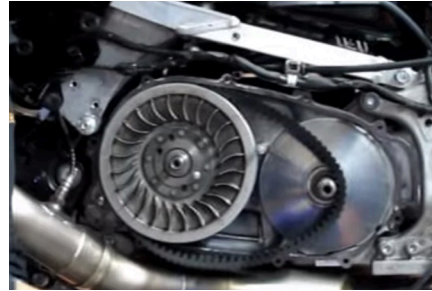

3. Introducir arandela J.Costa.

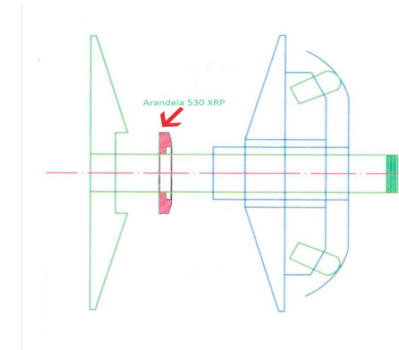

4. Fix the J.Costa variator, it must be repeat the washers position as original variator.

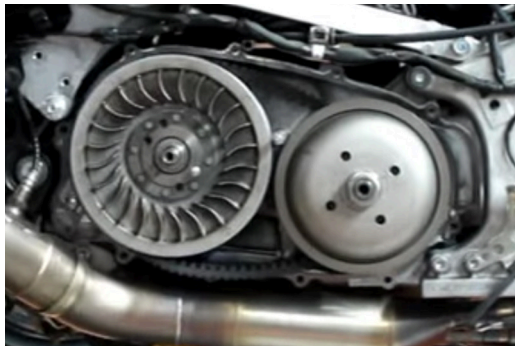

5. Block the correct par pulley.

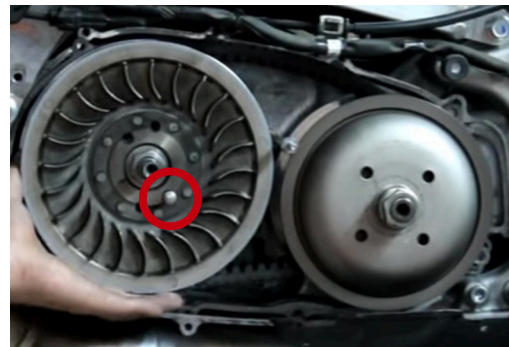

6. Fix the tool for bloquing the variator and tighten with the dynamometric tool to **16kg/160Nm**.

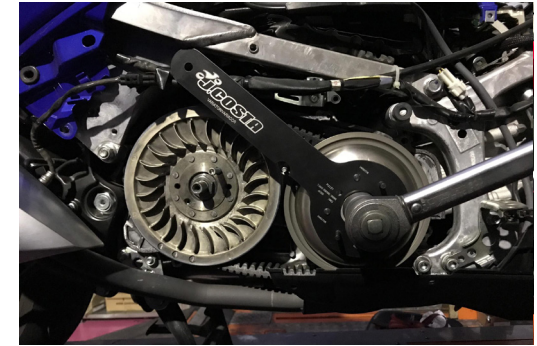

### T-MAX 530 VARIATOR CUTTING

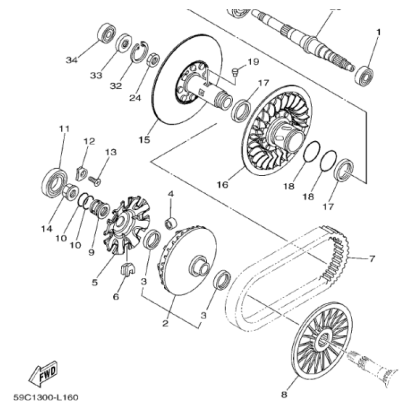

### T-MAX 500 VARIATOR CUTTING

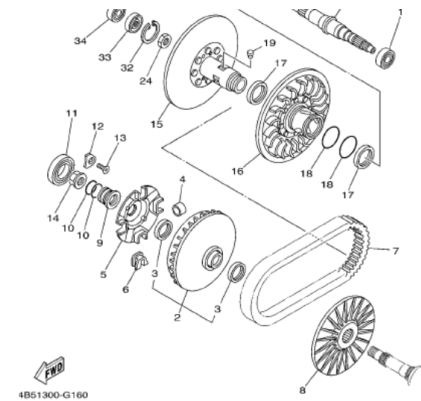

### T-MAX 560 VARIATOR CUTTING

